

## Refrigeration - an introduction to the basics

*Danfoss*

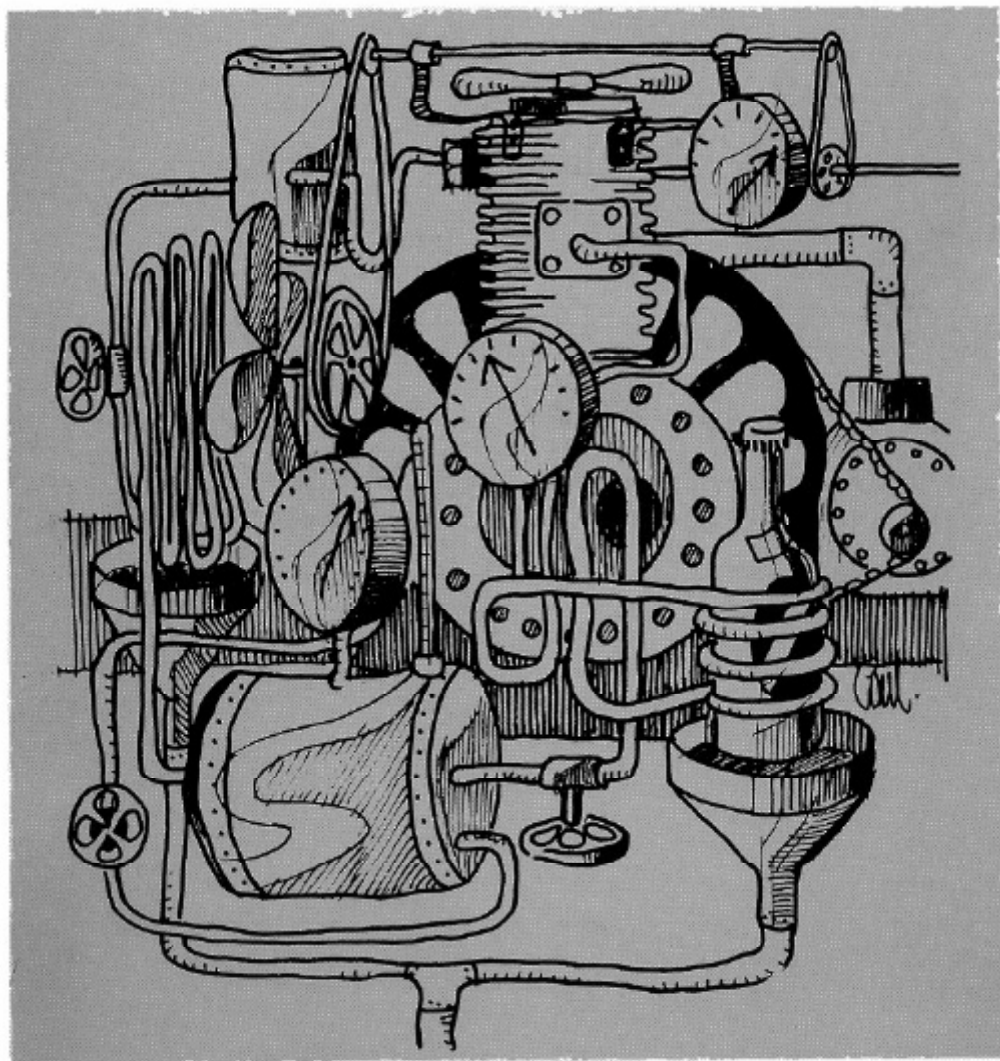



# **Refrigeration - an introduction to the basics**

# **Refrigeration - an introduction to the basics**

## **Contents**

1. Introduction
  2. Fundamental terms
    - 2.1 The SI system
    - 2.2 Pressure
    - 2.3 Heat
    - 2.4 Conditional changes in substances
    - 2.5 Evaporating heat
    - 2.6 Superheat
    - 2.7 The condensation process
    - 2.8 Temperature/enthalpy diagram
    - 2.9 Pressure/enthalpy diagram
  3. Refrigerant circuit
    - 3.1 Evaporator
    - 3.2 Compressor
    - 3.3 Compressor, method of operation
    - 3.4 Condenser
    - 3.5 Expansion process
    - 3.6 High and low pressure sides of the refrigeration plant
  4. Refrigeration process, pressure/enthalpy diagram
  5. Refrigerants
    - 5.1 General requirements
    - 5.2 Fluorinated refrigerants
    - 5.3 Ammonia  $\text{NH}_3$
    - 5.4 Secondary refrigerants
  6. Refrigeration plant main components
    - 6.1 Compressor
    - 6.2 Condenser
    - 6.3 Expansion valve
    - 6.4 Evaporation systems
  7. The practical build-up of a refrigeration plant
-

## **Forward**

This Danfoss publication must be regarded as a supplement to the comprehensive literature on refrigeration that is available today and which is primarily aimed at readers with a professional relationship to the refrigeration industry/trade e.g. refrigeration engineers and installers.

The contents of this book are intended to interest those who are not engaged every day with refrigeration plant but who wish to extend their knowledge on the basic principles of appliances they see every day.

When compiling the material for the booklet a deliberate attempt was made to provide a thorough description of the elementary principles involved together with an explanation in everyday language of the practical design of the individual components.

Nordborg

## About refrigeration

### 1. Introduction

The job of a refrigeration plant is to cool articles or substances down to, and maintain them at a temperature lower than the ambient temperature. Refrigeration can be defined as a process that removes heat.

The oldest and most well known among refrigerants are ice, water and air. In the beginning the sole purpose was to conserve food. The Chinese were the first to find out that ice increased the life and improved the taste of drinks and for centuries Eskimos have conserved food by freezing it.

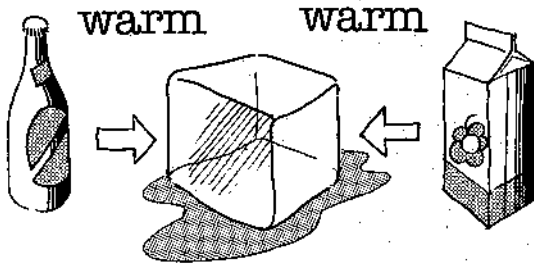

At the beginning of the last century, terms like bacteria, yeast, mould, enzymes, etc. were known. It had been discovered that the growth of micro-organisms is temperature-dependent, that growth declines as temperature falls, and that growth becomes very slow at temperatures below  $+10^{\circ}\text{C}$ .

As a consequence of this knowledge it was now possible to use refrigeration to conserve foodstuffs and natural ice came into use for this purpose.

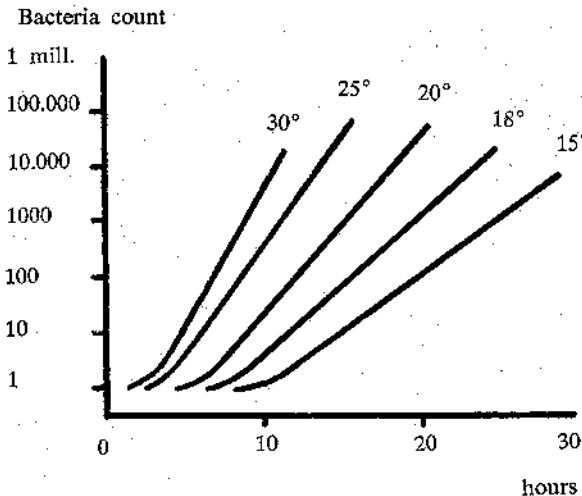

The first mechanical refrigerators for the production of ice appeared around the year 1860. In 1880 the first ammonia compressors and insulated cold stores were put into use in the USA.

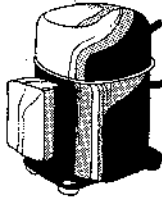

Electricity began to play a part at the beginning of this century and mechanical refrigeration plant became common in some fields: e.g. breweries, slaughterhouses, fishery, ice production, for example.

After the Second World War the development of small hermetic refrigeration compressors took hold in earnest and refrigerators and freezers began to take their place in the home. Today, these appliances are regarded as normal household necessities.

There are countless applications for refrigeration plant now. Examples are:

- foodstuff conservation
- process refrigeration
- air conditioning plant
- drying plant
- fresh water installations
- refrigerated containers
- heat pumps
- ice production
- freeze drying

In fact, it is difficult to imagine life without refrigeration and freezing – there impact on our existence is much greater than most people imagine.

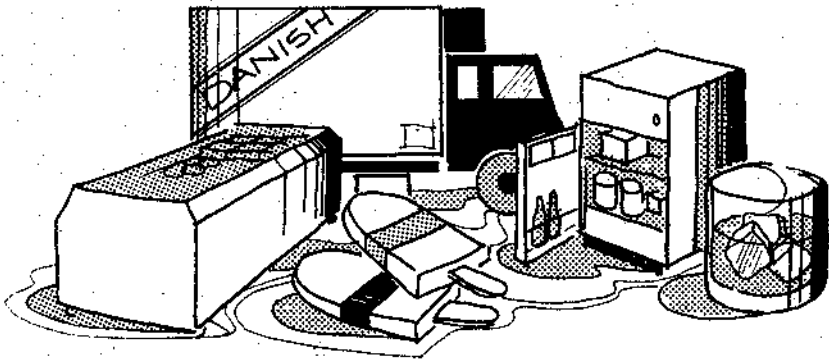

## 2. Fundamental terms

### 2.1 The SI system

On an international level, agreement has been reached on the use in the future of the "SI system" (Système International d'Unités) as a replacement for the metric system.

Designation	Metric system	SI-system
Temperature	°C	°K °C
Force	kilopond	Newton
Pressure	at-ata ato mm Hg	Pascal bar
Work	kpm kcal	Joule
Power	hp kcal/h	Watt
Enthalpy	kcal/kg	Joule/kg

It will be some time before this system has been generally incorporated in the refrigeration industry, but because many industrial countries have worked out standards and the accompanying legislation, it is necessary for everyone to become accustomed to the day-to-day use of SI units.

To ease the transition from the metric system to the SI system Danfoss at present follow the metric system and parenthesize the appropriate SI units, i.e. the method used throughout this booklet.

### 2.2 Pressure

When a force is applied to a surface, the effect produced is dependent on the size of that surface. As an obvious example, a man wearing skis can stand on snow without sinking very deep. That is to say, the skis distribute the weight of the man over a large surface so that his weight per unit of area on the surface of the snow becomes less.



Pressure is defined as the relation between the force exerted and the size of the area. It is measured in different units, depending on the purpose of the measurement. Of these,  $\text{kp/cm}^2$  is the most common in the metric system. This unit is often abbreviated to "at" and designates one technical atmosphere.

Normally, air pressure is  $1.033 \text{ kp/cm}^2$  and designates one physical atmosphere. The abbreviation here is "atm".

Different pressure designations will be obtained depending on which zero vacuum point is chosen. If absolute zero vacuum is used the designation will be "ata" where "a" stands for "absolute". This unit is most frequently used within refriger-



ation, even though "ato" can be seen on pressure gauges. "Ata" stands for "over-pressure" referring to the physical atmosphere. Thus, the zero point corresponds to 1 atm and 1.033 ata.

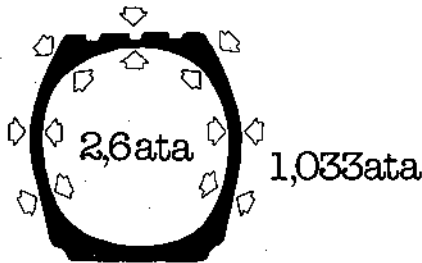

Another, frequently met, unit of measurement for pressure is mm mercury column, abbreviated to mm Hg. Air pressure corresponds to 760 mm Hg which, again, corresponds to 1 atm and 1.033 ata.

Finally, in connection with water circulation pumps, the designation "meter water gauge" is often met. The abbreviation is m wg and 10 m wg corresponds to 1 ata, 10.33 m wg to 1 atm.

The unit for pressure in the SI system is the Newton/m<sup>2</sup>, also called a "pascal" (Pa). Since this unit represents such a small quantity in relation to, for example, refrigeration, the unit 1 bar = 10<sup>5</sup> Pa is used instead. Fortunately, 1 at = 0.9807 bar ≈ 1 bar. That is why in practice it is often possible to use the same sizes whether the SI or metric system is involved in both systems.

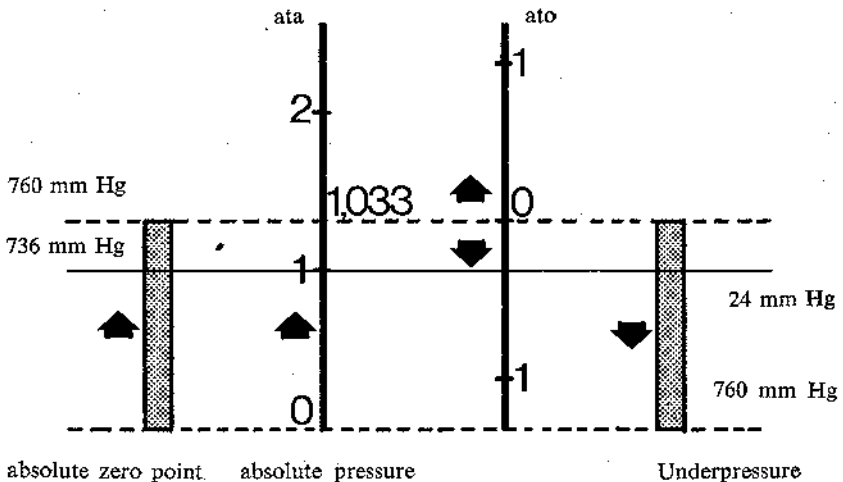

### 2.3 Heat

Heat is one form of energy which cannot be seen. Only its effect is apparent and the measurement of this effect is the way heat is defined.

The unit for heat in the metric system is the calorie (cal) which is defined as the amount of heat necessary to increase the temperature of 1 g water from 15°C to 16°C. In refrigeration it is normal to use the kilocalorie (kcal) which is equal to 1000 calories.

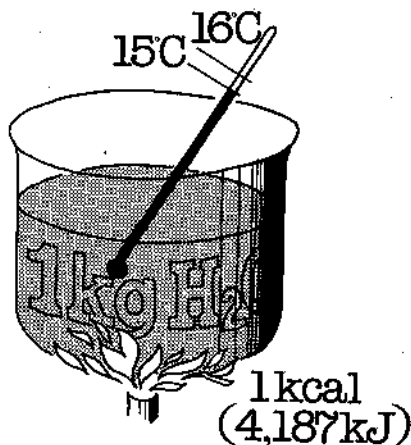

In the SI system the unit for all forms of work, including heat, is the joule (J).  
Converting from metric to SI:

$$1 \text{ cal} = 4.187 \text{ J}$$

$$1 \text{ kcal} = 4.187 \text{ kJ}$$

There is a great difference in how much heat is required to increase the temperature of various substances by 1°C; 1 kg iron needs 0.114 kcal whereas 1 kg air needs 0.24 kcal. The "specific heat" of a substance is the amount of heat required to increase the temperature of 1 kg of the substance 1°C. The specific heat of different substances can be found in tables and is given in kcal/kg°C (kJ/kg°C).

### 2.4 Conditional changes in substances

Every substance can exist in three different forms: solid liquid and gas. Water is the most natural example – its solid form is ice, it lies all around us in liquid form and in gas form it is steam. Common to these three conditions is that the water molecules remain unchanged, i.e. water, ice and steam have the same atomic symbol,  $H_2O$ .

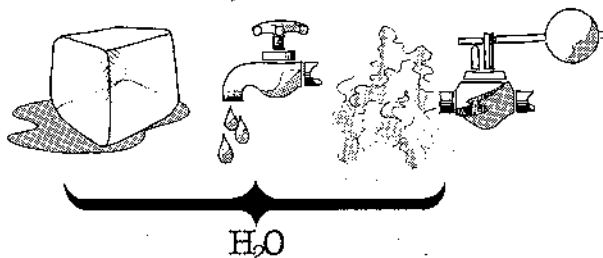

The temperature and pressure a substance is exposed to determines whether it exists in solid, liquid or gas form. The temperature at which a solid substance turns into a liquid is called the melting point. During melting the temperature does not change; all the heat applied goes into changing the substance from solid to liquid. Only when the substance has been melted will the further application of heat cause its temperature to rise further. Different substances have different melting points. Chocolate, for example, melts at  $26^{\circ}C$ .

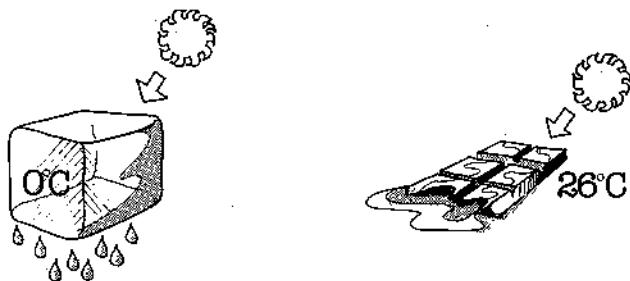

Here, an ice cabinet can be given as an example. Ice is applied at, say,  $-10^{\circ}C$  and becomes quickly heated to  $0^{\circ}C$  because it takes heat from the surroundings and from the foodstuffs in the cabinet, etc. Then, the ice will begin to melt and during the time it is melting the temperature will remain constant at  $0^{\circ}C$ . If fresh ice is not added melting will gradually be complete and the ice/water will collect in the tray in the bottom of the cabinet. The temperature of the cabinet will then rise and eventually reach room temperature.

The amount of heat that must be applied while the melting process takes place is known as the melting heat. This is defined as the amount of heat necessary to melt 1 kg substance which previously has been heated to melting point. Taking water as an example again, the melting heat of ice is 80 kcal (335 kJ).

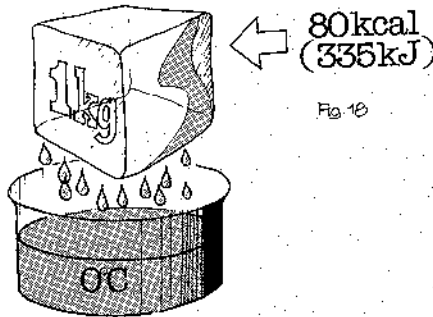

Fig. 10

An understanding of the process that takes place during the conditional change of a substance is important as far as refrigeration is concerned because:

- conditional change takes place at a constant temperature
- conditional change involves a relatively large amount of heat per kg substance.

### 2.5 Evaporating heat

Since the characteristics of water are easy to observe and since water behaves the same as most refrigerants it has been used as an example in this section.

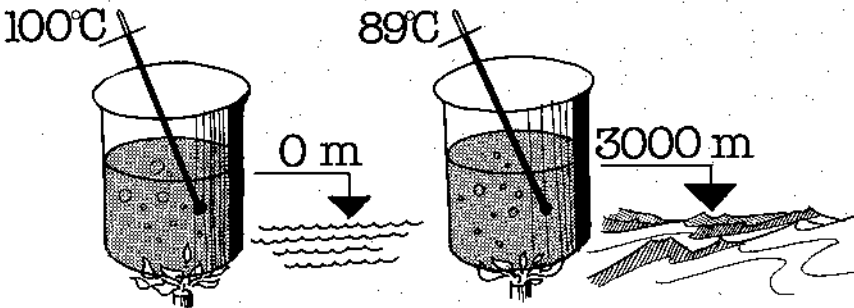

When water is heated, its temperature rises evenly until it begins to boil, its boiling point depending on the pressure applied to it. In an open vessel and at normal atmospheric pressure at sea level, 760 mm mercury column (Hg), water boils at 100°C.

If the pressure falls below atmospheric the boiling point will be lower than 100°C. For example, at a pressure of 531 mm Hg (equivalent to 3000 m above sea level) boiling point is 89°C.

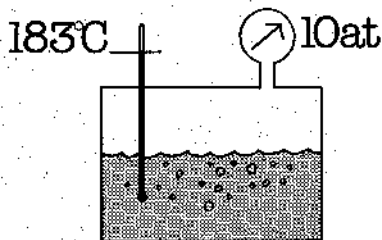

In a closed vessel, boiling point is determined by the steam pressure. If the pressure is higher than 760 mm Hg boiling point will be more than  $100^{\circ}\text{C}$ . For example, the boiling point of water is  $120^{\circ}\text{C}$  when pressure is 1 at over atmospheric and  $183^{\circ}\text{C}$  where pressure is 10 at over atmospheric. This principle is used in pressure cookers.

Water at boiling point is also called saturated liquid and, consequently, boiling point is also known as the saturation temperature. Any given pressure produces a corresponding boiling or saturation temperature and the values for water are contained in the table below.

Pressure	Temperature	Pressure	Temperature
ata	$^{\circ}\text{C}$	ata	$^{\circ}\text{C}$
0.2	60	2.0	120
0.4	75	4.0	143
0.6	86	6.0	158
0.8	93	8.0	170
1.0	99	10.0	179

The amount of energy applied to make a liquid at boiling point evaporate is called the evaporating heat. At atmospheric pressure (760 mm Hg) the amount required to evaporate 1 kg water at  $100^{\circ}\text{C}$  to steam with a temperature of  $100^{\circ}\text{C}$  is 539 kcal (2260 kJ). In the case of water, 1 kg dry saturated steam is formed. If a smaller amount of heat is applied only part of the liquid will evaporate and the result will be a mixture consisting of saturated liquid and saturated steam.

Evaporating heat is also called *latent* heat, i.e. the heat that can be applied to a substance without causing its temperature to change. The converse is *sensible* heat which is the heat applied to or taken from a substance when it is at a temperature lying over or under boiling point or melting point.

### 2.6 Superheat

If heat is applied to a saturated vapour the result will be superheated vapour, the heat applied being called superheat. Since a conditional change has already taken place, sensible heat enters the picture – it is this that causes a temperature increase in the vapour. The specific heat of a medium changes at the transition from the liquid phase to the vapour phase. For example, only 0.45 kcal (1.9 kJ) is required to heat 1 kg steam 1°C, whereas the same temperature increase in water requires 1 kcal (4.187 kJ).

### 2.7 The condensation process

The reverse of a conditional change from liquid to vapour is from vapour to liquid, a process which is called condensation (precipitation). Instead of applying a certain quantity of heat it is necessary to remove the same quantity to transform vapour into liquid. Again, pressure determines the temperature at which condensation occurs.

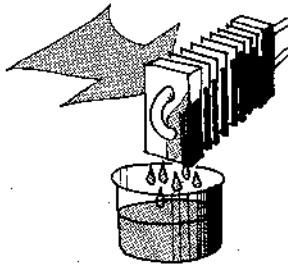

### 2.8 Temperature/enthalpy diagram

The characteristics of a substance can be illustrated in a temperature/enthalpy diagram where enthalpy is the abscissa and temperature the ordinate. Enthalpy is often called heat content and is the sum of the energy applied to a medium. For clarification, water at atmospheric pressure has been chosen as an example.

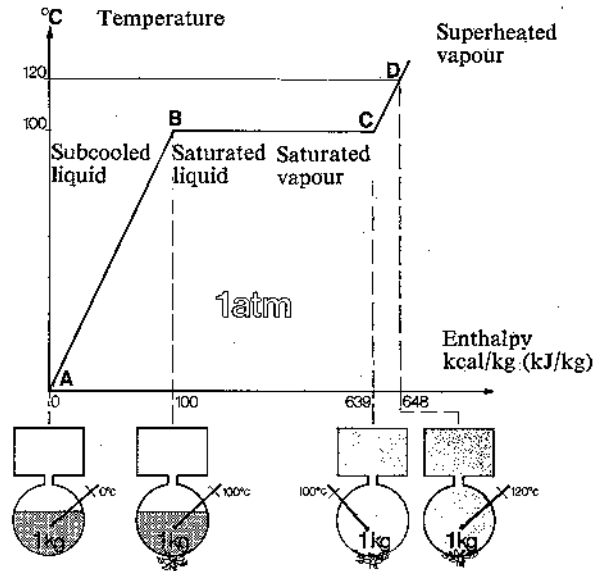

Temperature/enthalpy diagram

The diagram begins with water at a temperature of  $0^{\circ}\text{C}$  where the enthalpy is also 0 (kcal/kg water). The application of sensible heat produces a conditional change from A to B (the evaporating temperature of Water). The difference between A and B corresponds to a temperature rise of  $100^{\circ}\text{C}$ . As previously mentioned, every  $1^{\circ}\text{C}$  rise in temperature requires 1 kcal (4.187 kJ) therefore the total heat that must be applied here is 100 kcal. Thus, the heat content = enthalpy becomes 100 kcal/kg  $\text{H}_2\text{O}$  (418.7 J/kg).

Line B-C corresponds to the latent heat (evaporating heat) that is required to transform 1 kg water (point B) to dry saturated steam (point C). The evaporating heat of water at atmospheric pressure is, as previously mentioned, 539 kcal/kg  $\text{H}_2\text{O}$  and the enthalpy is the sum of the total heat applied =  $100 + 539 = 639$  kcal/kg  $\text{H}_2\text{O}$ . It is important to note that no temperature increase occurs between B and C.

Line C-D shows the effect of the sensible heat on the steam, i.e. the superheat. The specific heat of steam has been given as 0.45 kcal/kg  $\text{H}_2\text{O}$  (1.88 kJ/kg  $\text{H}_2\text{O}$ ). In this example the temperature rise shown is  $20^{\circ}\text{C}$  and the necessary amount of heat therefore becomes  $20 \times 0.45 = 9$  kcal/kg  $\text{H}_2\text{O}$ . The enthalpy is again the sum of the total applied heat =  $639 + 9 = 648$  kcal/kg  $\text{H}_2\text{O}$ .

### 2.9 Pressure/enthalpy diagram

As was previously explained, the temperature/enthalpy relation is dependent on pressure and under para 2.8 a diagram was described using water as an example. However, to show the temperature/enthalpy characteristics for media would involve making diagrams for all possible pressures. Since this is clearly impractical a more flexible pressure/enthalpy diagram is used instead. Such a diagram is shown in the figure below. A pressure is chosen for the ordinate, as a rule graduated in accordance with a logarithmic scale. In refrigeration it is necessary to work with different pressures and temperatures and this diagram offers a practical way of graphically determining energy exchange in a plant.

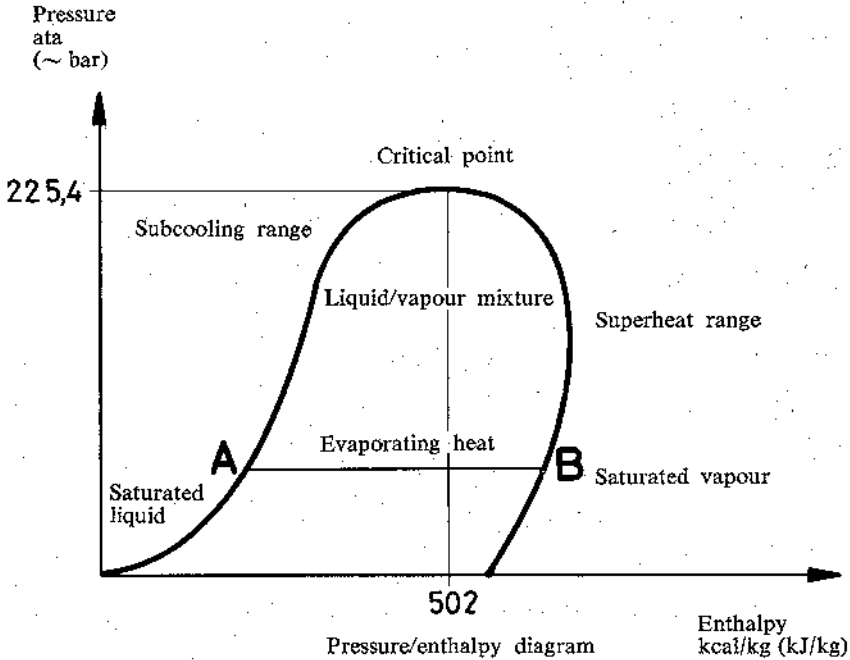



### 3. Refrigerant circuit

The physical terms for the refrigeration process have been dealt with in the foregoing, even though for practical reasons water is not used as a refrigerant. A simple refrigerant circuit is built up as shown in the sketch below. In what follows, the individual components are described to clarify a final overall picture.

#### 3.1 Evaporator

A refrigerant in liquid form will absorb heat when it evaporates and it is this conditional change that produces cooling in a refrigerating process. If a refrigerant at the same temperature as ambient is allowed to expand through a hose with an outlet to atmospheric pressure, heat will be taken up from the surrounding air and evaporation will occur at a temperature corresponding to atmospheric pressure. If in a certain situation pressure on the outlet side (atmospheric pressure) is changed, a different temperature will be obtained since this is analogous to the original temperature – it is pressure-dependent.

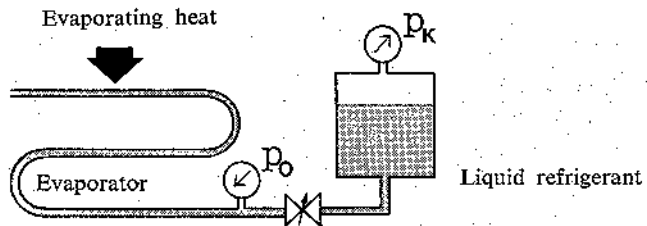

The component where this occurs is the evaporator, whose job it is to remove heat from the surroundings, i.e. to produce refrigeration.

#### 3.2 Compressor

The refrigeration process is, as implied, a closed circuit. The refrigerant is not allowed to expand to free air.

When the refrigerant coming from the evaporator is fed to a tank the pressure in the tank will rise until it equals the pressure in the evaporator. Therefore, refrigerant flow will cease and the temperature in both tank and evaporator will gradually rise to ambient.

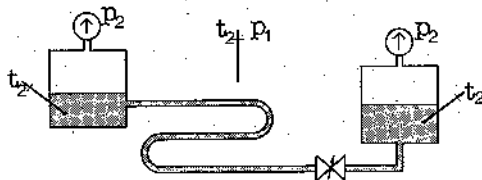

To maintain a lower pressure, and, with it a lower temperature it is necessary to remove vapour. This is done by the compressor which sucks vapour away from the evaporator. In simple terms, the compressor can be compared to a pump that conveys vapour in the refrigerant circuit.

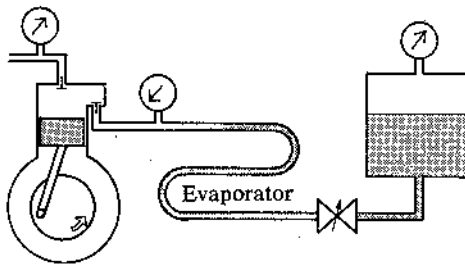

In a closed circuit a condition of equilibrium will always prevail. To illustrate this, if the compressor sucks vapour away faster than it can be formed in the evaporator the pressure will fall and with it the temperature in the evaporator. Conversely, if the load on the evaporator rises and the refrigerant evaporates quicker, the pressure and with it the temperature in the evaporator will rise.

### 3.3 Compressor, method of operation

Refrigerant leaves the evaporator either as saturated or weak superheated vapour and enters the compressor where it becomes compressed. Compression is carried out as in a petrol engine, i.e. by the movement of a piston.

The compressor requires energy and does work. This work is transferred to the refrigerant vapour and is called the compression input.

Piston compressor

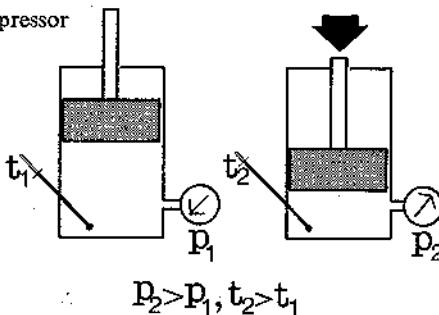

Because of the compression input, vapour leaves the compressor at a different pressure and the extra energy applied causes strong superheating of the vapour.

Compression input is dependent on plant pressure and temperature. More work is of course required to compress 1 kg vapour 10 at (~ bar) than to compress the same amount 5 at (~ bar).

### 3.4 Condenser

The refrigerant gives off heat in the condenser, and that heat is transferred to a medium having a lower temperature. The amount of heat given off is the heat absorbed by the refrigerant in the evaporator plus the heat created by compression input.

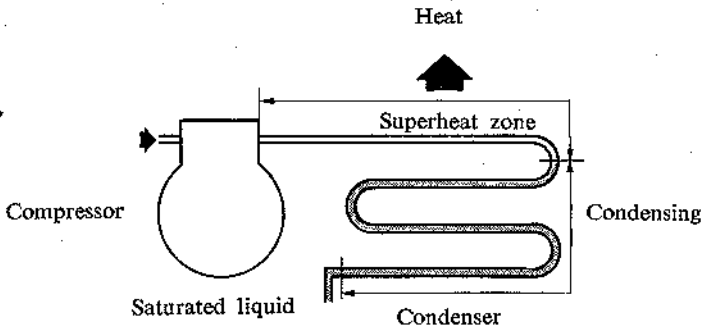

The heat transfer medium can be air or water, the only requirement being that the temperature is lower than that which corresponds to the condensing pressure. The process in the condenser can otherwise be compared with the process in the evaporator except that it has the opposite "sign", i.e. the conditional change is from vapour to liquid.

### 3.5 Expansion process

Liquid from the condenser runs to a collecting tank, the receiver. This can be likened to the tank mentioned under para 3.1 on the evaporator.

Pressure in the receiver is much higher than the pressure in the evaporator because of the compression (pressure increase) that has occurred in the compressor. To reduce pressure to the same level as the evaporating pressure a device must be inserted to carry out this process which is called throttling or expansion. Such a device is therefore known either as a throttling device or an expansion device. As a rule a valve is used – a throttle or expansion valve.

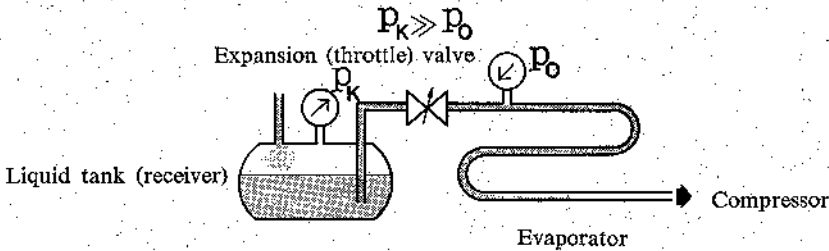

Ahead of the expansion valve the liquid will be a little under boiling point. By suddenly reducing pressure a conditional change will occur; the liquid begins to boil and evaporate. This evaporation takes place in the evaporator and the circuit is thus complete.

### 3.6 High and low pressure sides of the refrigeration plant

There are many different temperatures involved in the operation of a refrigeration plant since there are such things as subcooled liquid, saturated liquid, saturated vapour and superheated vapour. There are however, in principle, only two pressures; evaporating pressure and condensing pressure. The plant then is divided into high pressure and low pressure sides, as shown in the sketch.

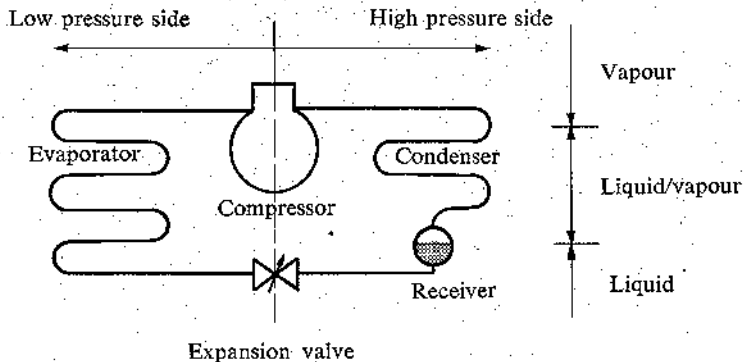

#### 4. Refrigeration process, pressure/enthalpy diagram

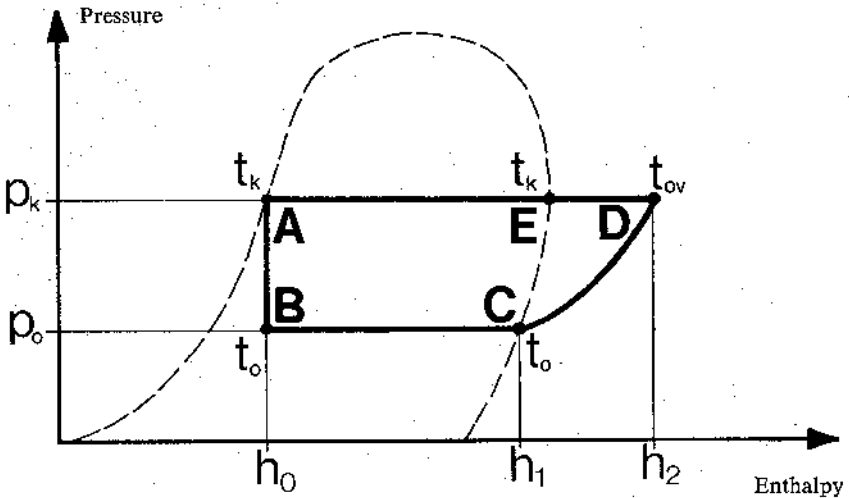

The condensed refrigerant in the receiver is in condition A which lies on the line for the boiling point of the liquid. The liquid has thus a temperature  $t_k$  (condensing temperature), a pressure  $p_k$  (condensing pressure) and an enthalpy  $h_0$ .

When the liquid passes through the expansion valve its condition changes from A to B. This conditional change is brought about by the liquid boiling because of the drop in pressure to  $p_o$ . At the same time a lower boiling point is produced,  $t_o$ , because of the drop in pressure.

At the expansion valve, as heat is neither applied nor removed, the enthalpy is still  $h_0$ .

At the evaporator inlet there is a mixture of liquid and vapour while at the evaporator outlet point C is saturated vapour. Pressure and temperature are the same at point B but since the evaporator has absorbed heat from the surroundings the enthalpy has changed to  $h_1$ .

When the refrigerant passes through the compressor its condition changes from C to D. Pressure rises to condensing pressure  $p_k$ . The temperature rises to  $t_{ov}$  which is higher than the condensing temperature  $t_k$  because the vapour has been strongly superheated. More energy in the form of heat has also been introduced and the enthalpy therefore changes to  $h_2$ .

At the condenser inlet, point D, the condition is thus one of superheated vapour at pressure  $p_k$ . Heat is given off from the condenser to the surroundings so that the enthalpy again changes to main point A. First in the condenser there occurs a conditional change from strongly superheated vapour to saturated vapour (point E), then a condensation of the saturated vapour. From point E to point A the temperature (condensing temperature) remains the same, in that condensation and evaporation occur at constant temperature.

In practice the refrigerating process will appear slightly differently in a pressure/enthalpy diagram because normally less superheating of the vapour from the evaporator occurs and the liquid temperature ahead of the expansion valve can be weakly subcooled because of the heat exchange with the surroundings.

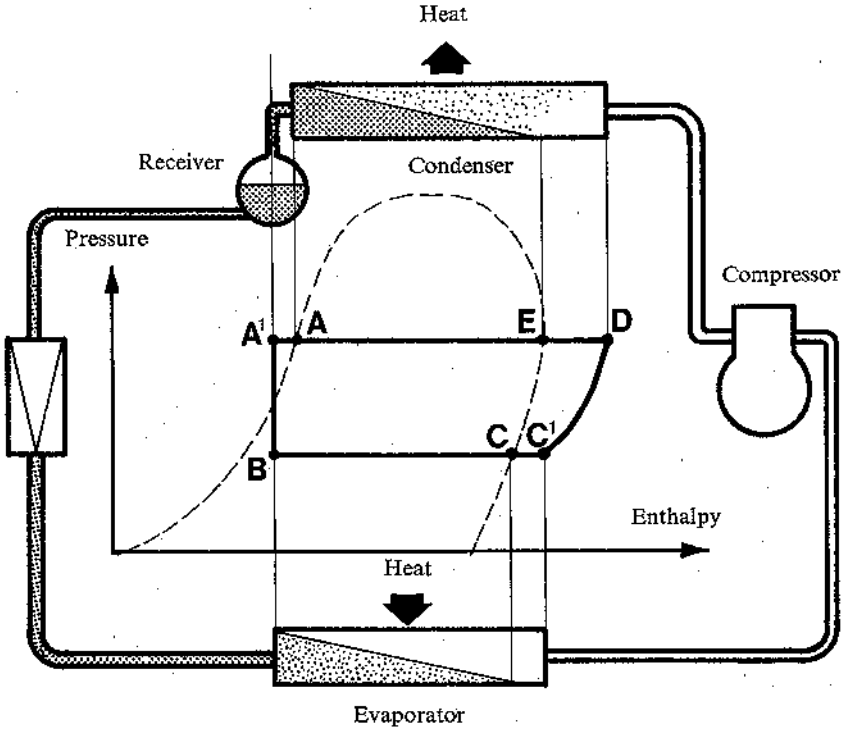

## 5. Refrigerants

### 5.1 General requirements

During the examination of the refrigeration process the question of refrigerants was not discussed because it was not necessary to do so in connection with the basic physical principles of the conditional change of substances.

It is well-known however that in practice different refrigerants are used according to what the application is and what the requirements are. The most important factors are as follows:

- The refrigerant ought not to be poisonous. Where this is impossible, the refrigerant must have a characteristic smell or must contain a tracer so that leakage can quickly be observed.
- The refrigerant ought not to be flammable nor explosive. Where this condition cannot be met the same precautions as in the first point must be observed.
- The refrigerant ought to have reasonable pressure, preferably a little higher than atmospheric pressure at the temperatures required to be held in the evaporator.
- To avoid heavy refrigerator design, the pressure which corresponds to normal condensing pressure must not be too high.
- Relatively high evaporating heat is required so that heat transmission can occur with least possible circulating refrigerant.
- Refrigerant vapour ought not to have too high a specific volume because this is a determinant for compressor stroke at a particular cold yield.
- The refrigerant must be chemically stable at the temperatures and pressures normal in a refrigeration plant.
- The refrigerant ought not to be corrosive and must not, either in liquid or vapour form, attack normal design materials.
- The refrigerant must not break down lubricating oil.
- The refrigerant must be easy to obtain and handle.
- The refrigerant must not cost too much.

### 5.2 Fluorinated refrigerants

Fluorinated refrigerants always carry the designation "R" followed by a number, e.g. R 11, R 12, R 22 and R 502. But they are often met bearing their trade names.

The fluorinated refrigerants all have the following features:

- Vapour is smell-free and non-irritant.
- Non-poisonous, except that in the presence of fire the vapour can give off acid and phosgene which are very poisonous.
- Non-corrosive.
- Non-inflammable nor explosive.

The most common fluorinated refrigerants are:

**R 11**, which is most used in air conditioning and heat pump installations because it has a relatively high boiling point:  $+24^{\circ}\text{C}$ . Its chemical formula is:  $\text{C Cl}_3\text{F}$ .

**R 12**, which like R 11 is a chemical compound of the methane group with the formula  $\text{C Cl}_2\text{F}_2$  and has a normal boiling point of  $-30^{\circ}\text{C}$ . R 12 is usually only used on small refrigeration plant because, among other things, the evaporating heat per amount of circulating refrigerant is relatively small.

**R 22**. This refrigerant is used in freezer plant etc. where still lower temperatures are required. Its boiling point is  $-41^{\circ}\text{C}$ . The evaporating heat per amount of circulating refrigerant is somewhat better than for R 12. Its chemical formula is  $\text{CHF}_2\text{Cl}$ .

**R 502**. An azeotropic mixture of refrigerants R 22 and R 115 ( $\text{CClF}_2\text{CF}_3$ ). The word "azeotropic" means that the refrigerant will be found in the same concentration over the whole plant. The boiling point is still lower than for R 22, i.e.  $-46^{\circ}\text{C}$ .

Apart from these fluorinated refrigerants there is a long series of others not seen very often today: R 12B1, R 13, R 13B1, R 114, R 115, R 500.

### 5.3 Ammonia $\text{NH}_3$

Ammonia  $\text{NH}_3$  is used extensively in large industrial refrigeration plant. Its normal boiling point is  $-33^{\circ}\text{C}$ .

Ammonia has a characteristic smell even in small concentrations in air. It cannot burn, but is explosive when mixed with air in a volume percentage 13–28.

Because of corrosion, copper or copper alloys must not be used in ammonia plant.

### 5.4 Secondary refrigerants

The refrigerants mentioned above are often designated "primary refrigerants". As an intermediate link in heat transmission from the surroundings to the evaporator the so-called "secondary refrigerants" can be used, e.g. water, brine and atmospheric air.



## 6. Refrigeration plant main components

### 6.1 Compressor

The job of the compressor is to suck vapour from the evaporator and force it into the condenser. The most common type is the piston compressor, but other types have won acceptance, e.g. centrifugal and screw compressors.

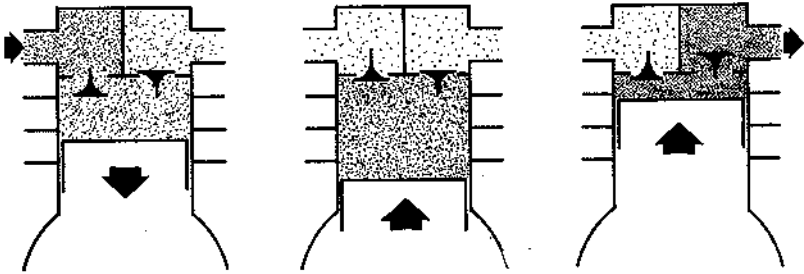

The piston compressor covers a very large capacity range, right from small single cylinder models for household refrigerators up to 8 to 10 cylinder models with a large swept volume for industrial applications.

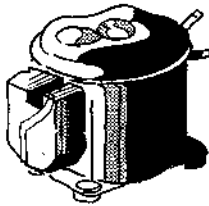

In the smallest applications the hermetic compressor is used, where compressor and motor are built together as a complete hermetic unit.

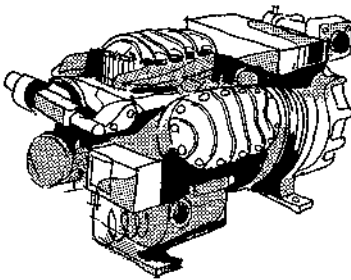

For larger plant the most common is the semi-hermetic compressor. The advantage here is that shaft glands can be avoided; these are very difficult to replace when they begin to leak. However, the design cannot be used on ammonia plant since this refrigerant attacks motor windings.

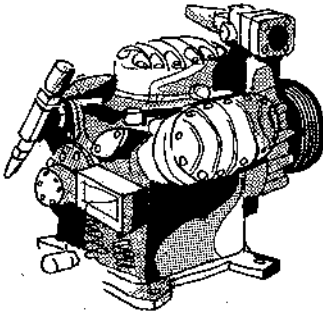

Still larger Freon compressors, and all ammonia compressors, are designed as "open" compressors, i.e. with the motor outside the crankcase. Power transmission can be direct to the crankshaft or through a V-belt drive.

For quite special applications there is the oil-free compressor. But lubrication of bearings and cylinder walls with oil is normally always necessary. On large refrigeration compressors oil is circulated by an oil pump.

### 6.2 Condenser

The purpose of the condenser is to remove the amount of heat that is equal to the sum of the heat absorbed in the evaporator and the heat produced by compression. There are many different kinds of condensers.

*Shell and tube condenser.* This type of condenser is used in applications where sufficient cooling water is available. It consists of a horizontal cylinder with welded-on flat end caps which support the cooling tubes. End covers are bolted to the end plates.

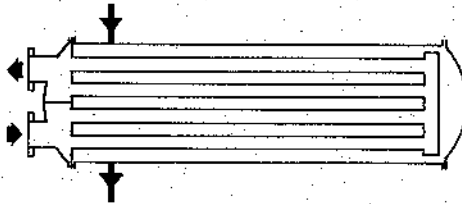

The refrigerant condensate flows through the cylinder, the cooling water through the tubes. The end covers are divided into sections by ribs. The sections act as reversing chambers for the water so that it circulates several times through the condenser. As a rule, the water becomes heated 5–10°C when it has passed through a condenser.

If it is desirable or necessary to cut down on the amount of water an *evaporating condenser* can be used instead. This type of condenser consists of a housing in which there is a condensing coil, water distribution tubes, deflection plates and fans.

The warm refrigerant vapour is led to the top of the condensing coil after which it condenses and runs from the bottom of the coil as liquid.

Water distribution tubes with nozzles are placed over the condensing coil so that water is spread over and runs down the coil.

The fans direct a strong flow of air across the condensing coil.

When the falling drops of water meet the upward air flow some of the water will evaporate. This absorbs the necessary evaporating heat from the refrigerant vapour and causes it to condense.

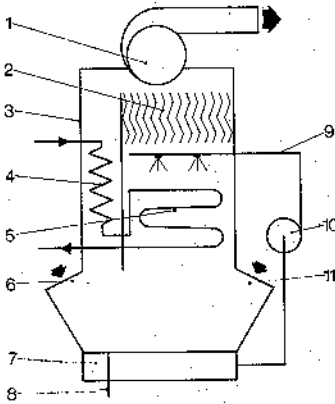

1. Fan
2. Deflector plate
3. Outer covering
4. Superheat remover
5. Condenser tubing
6. Air intake
7. Collecting tray
8. Overflow pipe
9. Water distribution pipe
10. Water circulation pump
11. Air intake

The principal involving water evaporation is also used in connection with *cooling towers*. These are installed when the most practical is to place a shell and tube condenser near a compressor. The water is then circulated in a circuit between condenser and cooling tower.

In principle, the cooling tower is built up the same as the evaporating condenser, but instead of condensing elements there are deflector plates. Air is heated on its way through the tower by direct contact with the trickle of water travelling downwards and is able therefore to absorb an increasing amount of moisture coming from part-evaporation. In this way the cooling water loses heat. Water loss is made up by supplying more water.

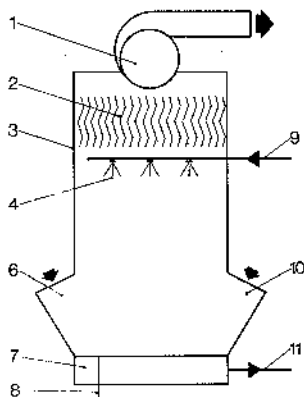

1. Fan
2. Deflector plate
3. Outer covering
4. Nozzle
6. Air intake
7. Collecting tray
8. Overflow pipe
9. Cooling water from condenser
10. Air intake
11. Cooling water return to condenser

It is possible to save 90–95 % water consumption by using evaporating condensers or cooling towers, when compared to the water consumption of shell and tube condensers.

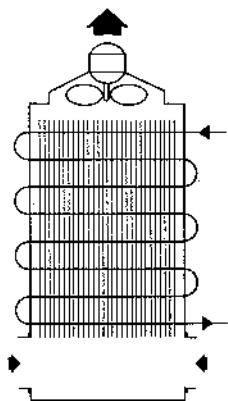

For one reason or another it is not always possible to use water for the condensing process. In such cases an *air-cooled condenser* must be used. Since air has poor heat transfer characteristics, compared with water, a large surface on the outside of the condensing tubes is necessary. This is achieved using large ribs or fins and, in addition, by ensuring generous air circulation mechanically.

### 6.3 Expansion valve

The main purpose of the expansion valve is to ensure a sufficient pressure differential between the high and low pressure sides of the plant.

The simplest way of doing this is to use a capillary tube inserted between the condenser and evaporator.

The capillary tube is however only used in small, simple appliances like refrigerators because it is not capable of regulating the amount of liquid that is injected into the evaporator. A regulating valve must be used for this process, the most usual being the thermostatic expansion valve, which consists of a valve housing, capillary tube and a bulb. The valve housing is fitted in the liquid line and the bulb is fitted on the evaporator outlet.

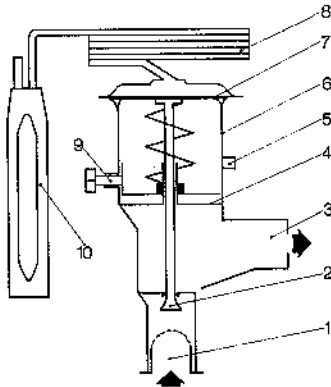

1. Inlet with strainer
2. Cone
3. Outlet
4. Bore
5. Connection for pressure equalizing
6. Spring housing
7. Diaphragm
8. Capillary tube
9. Spindle for setting spring pre-tension (opening superheat)
10. Bulb

The figure below shows an evaporator fed by a thermostatic expansion valve. A small amount of liquid is contained in a part of the bulb. The rest of the bulb, the capillary tube and the space above the diaphragm in the valve housing is charged with saturated vapour at a pressure corresponding to the temperature at the bulb. The space under the diaphragm is in connection with the evaporator and the pressure is therefore equal to the evaporating pressure.

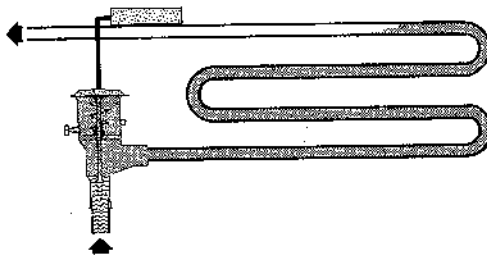

The degree of opening of the valve is determined by:

- The pressure produced by the bulb temperature acting on the top surface of the diaphragm.
- The pressure under the diaphragm which is equal to the evaporating pressure.
- The pressure of the spring acting on the underside of the diaphragm.

During normal operation, evaporation will cease some distance up in the evaporator. Then, saturated gas appears which becomes superheated on its way through the last part of the evaporator. The bulb temperature will thus be evaporating temperature plus superheat, e.g. at  $-10^{\circ}\text{C}$  evaporating temperature the bulb temperature could be  $0^{\circ}\text{C}$ .

If the evaporator receives too little refrigerant the vapour will be further superheated and the temperature at the outlet pipe will rise. The bulb temperature will then also rise and with it the vapour pressure in the bulb element since more of the charge will evaporate. Because of the rise in pressure the diaphragm becomes forced down, the valve opens and more liquid is supplied to the evaporator. Correspondingly, the valve will close more if the bulb temperature becomes lower.

Thermostatic expansion valves are produced in several versions and of course there are other types, but more lengthy explanations would add unnecessary complications.

#### 6.4 Evaporation systems

Depending on the application, various requirements are imposed on the evaporator. Evaporators are therefore made in a series of different versions.

*Evaporators for natural air circulation* are used less and less because of the relatively poor heat transfer from the air to the cooling tubes. Earlier versions were fitted with plain tubes, but now it is common to use ribbed tubes or finned elements.

Evaporator yield is increased significantly if *forced air circulation evaporators* are used. With an increase of air velocity the heat transfer from air to tube is improved so that for a given cold yield a smaller evaporator surface than for natural circulation can be used.

As the name implies, a *liquid cooled* cools down liquid. The simplest method is to immerse a coil of tube in an open tank. Closed systems are coming into use more and more. Here, tube coolers made similar to shell and tube condensers are employed.

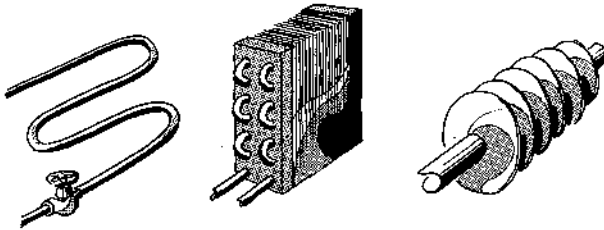

Plain tube evaporator

Finned evaporator

Ribbed tube evaporator

## 7. The practical build-up of a refrigeration plant

Sketch A shows the principle build-up of a refrigeration plant for a simple cold store – much like those that can be seen in butchers shops and supermarkets.

The compressor unit can, for example, be installed in an adjacent storage room with an outlet to fresh air. Such a unit consists of a compressor driven by V-belt and electric motor. Additionally, the base frame carries an air-cooled condenser and a receiver. A fan is mounted on the shaft of the electric motor to force air through the condenser and ensure the necessary degree of cooling. The line between compressor and condenser is known as the discharge line.

From the receiver, an uninsulated line, the liquid line, is taken out to the cold store where it is connected to the thermostatic expansion valve at the evaporator inlet. The evaporator is built up with close-pitch fins attached to tubes. It is also equipped with a fan for forced air circulation and a drip tray.

From the outlet side of the evaporator a line, the suction line, is led back to the compressor. The diameter of the suction line is somewhat larger than the liquid line because it carries vapour. For this reason the suction line is as a rule insulated.

Sketch B gives details of momentary temperatures in such a plant. At the evaporator outlet the pressure is 8.5 ata (~ bar) and the temperature is 60°C because of the presence of superheated gas. Temperature in the upper part of the condenser will quickly fall to saturation temperature, which at the pressure concerned will be 34°C, because superheat is removed and condensation begins.

Pressure at the receiver outlet will remain more or less the same, while subcooling of the liquid begins because the temperature has fallen by 2°C to 32°C.

In the evaporator a pressure of 2.2 ata (~ bar) and an evaporating temperature of -10°C are indicated. In the last part of the evaporator the vapour becomes superheated so that temperature at the thermostatic expansion valve bulb becomes +2°C, corresponding to the superheat set on the valve.

As shown in the sketch, air temperature will vary, in that the air will take up heat on its way round the store from products, walls, ceiling, etc. The temperature of the air blown across the condenser will also vary with the time of year.

A refrigeration plant must then be dimensioned according to the largest load it will be subjected to. To be able to accomodate smaller loads, facilities must exist in the plant for altering yield. The process of making such alterations is called regulation and it is precisely regulation that Danfoss automatic controls are made for. But that is a subject which is outside the scope of this publication.



A

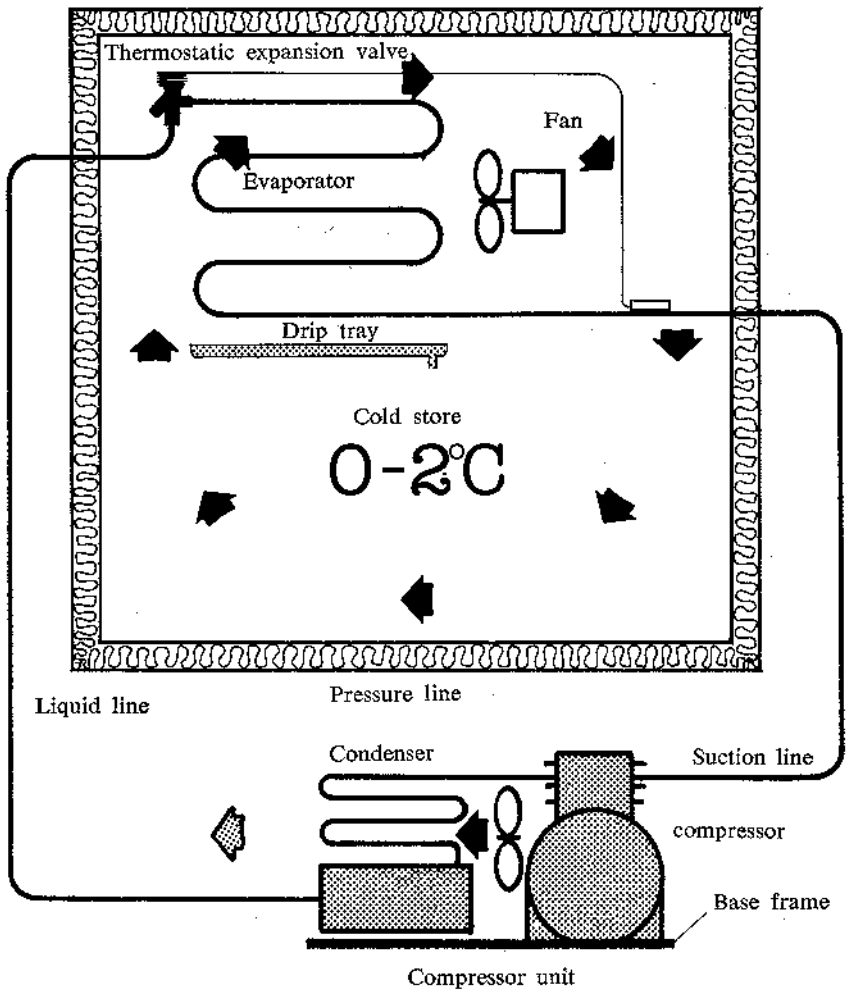

B

