

customer service

XT & XC Accessories

CAM-0608	Cam upgrade for 6-8mm line
CAM-0814	Cam upgrade for 8-14mm line
CAM-1216	Cam upgrade for 12-16mm line
X-HDLB	Aluminium Handle (Black) for XT/XC/XR
X-HDLG	Aluminium Handle (Grey) for XT/XC/XR
X-SIDE	Plastic side fairings for XT (pair)
X-LBL	Handle Labels English, French, German XAS, XA & XT
X-SMNT	Converts standard XT, XC for side mounting
CAM-0814L	Cam upgrade (lock-up version) Converts XT/XC to lock-open action
CAM-1216L	Cam upgrade (lock-up version) Converts XT/XC to lock-open action

Spinlock's after sales service is available worldwide through our distribution network. Should you need any help in obtaining spare parts, or advice with repairs, your local Spinlock expert can provide a fast and professional service.

*Le service après-vente Spinlock est garanti à travers le monde grâce à notre réseau de distribution.
Que vous ayez besoin d'un conseil ou de pièces détachées, contactez votre distributeur local qui vous apportera un service rapide et de qualité.*

customer support

AUSTRIA Peter Frisch GmbH T: +49 8936 5075	NORWAY Ingvald Skaane A/S T: +47 33 041 591	ARGENTINA Trimer S.A. T: +5411 4580 0444
BENELUX More Marine bv T: +31 172 506 820	POLAND Ma-jer T: +48 22 839 8874	BRAZIL Regatta Sport Ltd T: +55 11 3030 3400
DENMARK Columbus Marine A/S T: +45 46 1911 66	PORTUGAL Sailingfoz – Comercio de Artigos Nauticos, Lda T: +351 226 179 936	AUSTRALIA Spinlock Australia Pty Ltd T: +612 9905 9400
FINLAND Oy Vestek AB T: +358 9 887 0120	SLOVENIA Seaway d.o.o. T: +386 45 302 444	BRITISH VIRGIN ISLANDS Richardsons Rigging Services T: +284 494 2739
FRANCE InterDist T: +33 2 99 19 54 54	SPAIN Equipyacht s.l. T: +34 93 221 9219	HONG KONG Sky International T: +852 2827 5876
GERMANY Peter Frisch GmbH T: +49 8936 5075	SWEDEN Sportsmanship AB T: +46 31 939 400	NEW CALEDONIA Marine Corail Noumea T: +687 27 58 48
GIBRAL TAR H. Sheppard & Co Ltd T: +350 75148	SWITZERLAND Bucher & Walt SA T: +41 32 755 9500	NEW ZEALAND Power & Marine Ltd T: +6499 145 555
GREECE Perga SA T: +30 1412 5069	TURKEY Tursan A.S. T: +90 212 696 99 15	SOUTH AFRICA Central Boating (Pty) Ltd T: +27 21 424 8026
HUNGARY Pannon Yacht-Skipper Co.Ltd. T: +361 466 8320	UNITED KINGDOM Marathon Leisure Ltd T: +44 23 9263 7711	
ITALY Deck Marine SPA T: +39 02 569 5906	CANADA Transat Marine Ltd T: +1 705 721 0143	
MALTA RLR T: +356 335 591	USA Maritime Trading Company LLC T: +1 860 767 0468	

Entretien

Spinlock products are made from the best quality materials for durability and low maintenance in a harsh marine environment. Do not use mineral oil & solvent based lubricants like WD40™. The wrong lubricants will degrade and weaken forced plastic components, possibly causing sudden structure failure. They will also degrade the bearing properties of composite bushes.

or best result, flush regularly with fresh water and lubricate handle / cam bearing with silicone grease or spray.

Do not use mineral oil & solvent based lubricants like WD40™. The wrong lubricants will degrade and weaken forced plastic components, possibly causing sudden structure failure. They will also degrade the bearing properties of composite bushes.

Maintenance

Tous les produits Spinlock sont fabriqués dans les meilleurs matériaux dans un souci de qualité et d'entretien minimum malgré un environnement agressif.

Nettoyer régulièrement à l'eau douce pour chasser les dépôts de sel et une fois sec, appliquer un spray silicone ou la graisse Spinlock.

Né pas utiliser de lubrifiant à base de solvant du type "WD40" lubrifiant renforcé pouvant causer une suite rupture structurelle. De plus, ce type de lubrifiant réduit les propriétés de glissement des coussinets en composites.

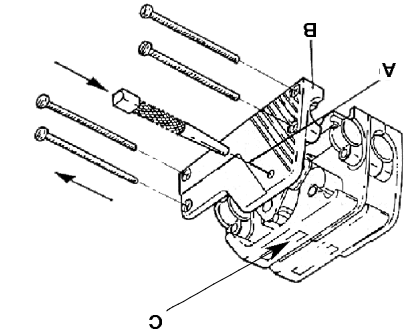

Full open lock

If the Powerclutch fails to stay full open in use, it is likely that the handle lever has been distorted. Replace with new handle or cam module.

Comment remplacer:

Retirer le bloqueur du pont.
Retirer les fixateurs (A) d'une joue(B) avec précautions.
Remarque comment est assurée le montage des pièces internes et changer la pièce défectueuse.
Reassembler le bloqueur.
Contrôler que l'axe butée (C) est bien positionné dans les trous borgnes, il ne doit pas y avoir de translation possible de cette pièce.
Contrôler le bon fonctionnement du bloqueur avant de le réfixer sur le pont sans oublier d'assurer un bonne étanchéité en utilisant le joint plat néoprène ou un mastic simple, assurez-vous qu'il axe (C) soit remplacé par un axe multiple, l'axe (C) devra aussi être remplacé par une pièce particulière :
XT12 (double) = 3X067A
XT13 = 3X068A
XT14 = 3X107A
XT15 = 3X126A

Four l'envoie sans frais de votre axe, veuillez contact Spinlock Direct, en indiquant le numéro de référence ci-dessus - our par Email: prosupport@spinlock.co.uk

Remove the Powerclutch from the deck.
Carefully unscrew fasteners (A) from sidefaring (B).
Remove one sidefaring leaving components located on fasteners.
Note how parts are assembled before removing faulty parts.
Reassemble with new parts.
Check top pin (C) is well located in blind holes, it should not be able to move from side to side.
Check function of clutch before resealing to deck using our neoprene installation gasket (X-CASK) or silicone sealant.
If replacing plastic sideplates on a single clutch, ensure that top pin (C) is replaced with top pin included with sideplates.
If replacing plastic sideplates on a multiple clutch, top pin (C) will also need to be replaced, by a special part.
XT12 = 3X067A
XT13 = 3X068A
XT14 = 3X107A
XT15 = 3X126A
For your top pin sent FO, C. Please contact Spinlock Direct, Tel: +44 (0) 1983 295555 Fax: +44 (0) 1983 295542

Handle (X-HDLB, X-HDLG, X-HDSL, X-HDLS)
Cam (CAM-0610/0814/1216/0814L/1216L)
pognée (X-HDLB, X-HDLG, X-HDSL, X-HDLS)
(X-SIDE, X-SIDEMB)

Remove the Powerclutch from the deck.
Carefully unscrew fasteners (A) from sidefaring (B).
Remove one sidefaring leaving components located on fasteners.
Note how parts are assembled before removing faulty parts.
Reassemble with new parts.
Check top pin (C) is well located in blind holes, it should not be able to move from side to side.
Check function of clutch before resealing to deck using our neoprene installation gasket (X-CASK) or silicone sealant.
If replacing plastic sideplates on a single clutch, ensure that top pin (C) is replaced with top pin included with sideplates.
If replacing plastic sideplates on a multiple clutch, top pin (C) will also need to be replaced, by a special part.
XT12 (double) = 3X067A
XT13 = 3X068A
XT14 = 3X107A
XT15 = 3X126A
For l'envoie sans frais de votre axe, veuillez contact Spinlock Direct, en indiquant le numéro de référence ci-dessus - our par Email: prosupport@spinlock.co.uk

Remove the Powerclutch from the deck.
Carefully unscrew fasteners (A) from sidefaring (B).
Remove one sidefaring leaving components located on fasteners.
Note how parts are assembled before removing faulty parts.
Reassemble with new parts.
Check top pin (C) is well located in blind holes, it should not be able to move from side to side.
Check function of clutch before resealing to deck using our neoprene installation gasket (X-CASK) or silicone sealant.
If replacing plastic sideplates on a single clutch, ensure that top pin (C) is replaced with top pin included with sideplates.
If replacing plastic sideplates on a multiple clutch, top pin (C) will also need to be replaced, by a special part.
XT12 (double) = 3X067A
XT13 = 3X068A
XT14 = 3X107A
XT15 = 3X126A
For l'envoie sans frais de votre axe, veuillez contact Spinlock Direct, en indiquant le numéro de référence ci-dessus - our par Email: prosupport@spinlock.co.uk

Remove the Powerclutch from the deck.
Carefully unscrew fasteners (A) from sidefaring (B).
Remove one sidefaring leaving components located on fasteners.
Note how parts are assembled before removing faulty parts.
Reassemble with new parts.
Check top pin (C) is well located in blind holes, it should not be able to move from side to side.
Check function of clutch before resealing to deck using our neoprene installation gasket (X-CASK) or silicone sealant.
If replacing plastic sideplates on a single clutch, ensure that top pin (C) is replaced with top pin included with sideplates.
If replacing plastic sideplates on a multiple clutch, top pin (C) will also need to be replaced, by a special part.
XT12 (double) = 3X067A
XT13 = 3X068A
XT14 = 3X107A
XT15 = 3X126A
For l'envoie sans frais de votre axe, veuillez contact Spinlock Direct, en indiquant le numéro de référence ci-dessus - our par Email: prosupport@spinlock.co.uk

Remove the Powerclutch from the deck.
Carefully unscrew fasteners (A) from sidefaring (B).
Remove one sidefaring leaving components located on fasteners.
Note how parts are assembled before removing faulty parts.
Reassemble with new parts.
Check top pin (C) is well located in blind holes, it should not be able to move from side to side.
Check function of clutch before resealing to deck using our neoprene installation gasket (X-CASK) or silicone sealant.
If replacing plastic sideplates on a single clutch, ensure that top pin (C) is replaced with top pin included with sideplates.
If replacing plastic sideplates on a multiple clutch, top pin (C) will also need to be replaced, by a special part.
XT12 (double) = 3X067A
XT13 = 3X068A
XT14 = 3X107A
XT15 = 3X126A
For l'envoie sans frais de votre axe, veuillez contact Spinlock Direct, en indiquant le numéro de référence ci-dessus - our par Email: prosupport@spinlock.co.uk

Remove the Powerclutch from the deck.
Carefully unscrew fasteners (A) from sidefaring (B).
Remove one sidefaring leaving components located on fasteners.
Note how parts are assembled before removing faulty parts.
Reassemble with new parts.
Check top pin (C) is well located in blind holes, it should not be able to move from side to side.
Check function of clutch before resealing to deck using our neoprene installation gasket (X-CASK) or silicone sealant.
If replacing plastic sideplates on a single clutch, ensure that top pin (C) is replaced with top pin included with sideplates.
If replacing plastic sideplates on a multiple clutch, top pin (C) will also need to be replaced, by a special part.
XT12 (double) = 3X067A
XT13 = 3X068A
XT14 = 3X107A
XT15 = 3X126A
For l'envoie sans frais de votre axe, veuillez contact Spinlock Direct, en indiquant le numéro de référence ci-dessus - our par Email: prosupport@spinlock.co.uk

Remove the Powerclutch from the deck.
Carefully unscrew fasteners (A) from sidefaring (B).
Remove one sidefaring leaving components located on fasteners.
Note how parts are assembled before removing faulty parts.
Reassemble with new parts.
Check top pin (C) is well located in blind holes, it should not be able to move from side to side.
Check function of clutch before resealing to deck using our neoprene installation gasket (X-CASK) or silicone sealant.
If replacing plastic sideplates on a single clutch, ensure that top pin (C) is replaced with top pin included with sideplates.
If replacing plastic sideplates on a multiple clutch, top pin (C) will also need to be replaced, by a special part.
XT12 (double) = 3X067A
XT13 = 3X068A
XT14 = 3X107A
XT15 = 3X126A
For l'envoie sans frais de votre axe, veuillez contact Spinlock Direct, en indiquant le numéro de référence ci-dessus - our par Email: prosupport@spinlock.co.uk

Remove the Powerclutch from the deck.
Carefully unscrew fasteners (A) from sidefaring (B).
Remove one sidefaring leaving components located on fasteners.
Note how parts are assembled before removing faulty parts.
Reassemble with new parts.
Check top pin (C) is well located in blind holes, it should not be able to move from side to side.
Check function of clutch before resealing to deck using our neoprene installation gasket (X-CASK) or silicone sealant.
If replacing plastic sideplates on a single clutch, ensure that top pin (C) is replaced with top pin included with sideplates.
If replacing plastic sideplates on a multiple clutch, top pin (C) will also need to be replaced, by a special part.
XT12 (double) = 3X067A
XT13 = 3X068A
XT14 = 3X107A
XT15 = 3X126A
For l'envoie sans frais de votre axe, veuillez contact Spinlock Direct, en indiquant le numéro de référence ci-dessus - our par Email: prosupport@spinlock.co.uk

Remove the Powerclutch from the deck.
Carefully unscrew fasteners (A) from sidefaring (B).
Remove one sidefaring leaving components located on fasteners.
Note how parts are assembled before removing faulty parts.
Reassemble with new parts.
Check top pin (C) is well located in blind holes, it should not be able to move from side to side.
Check function of clutch before resealing to deck using our neoprene installation gasket (X-CASK) or silicone sealant.
If replacing plastic sideplates on a single clutch, ensure that top pin (C) is replaced with top pin included with sideplates.
If replacing plastic sideplates on a multiple clutch, top pin (C) will also need to be replaced, by a special part.
XT12 (double) = 3X067A
XT13 = 3X068A
XT14 = 3X107A
XT15 = 3X126A
For l'envoie sans frais de votre axe, veuillez contact Spinlock Direct, en indiquant le numéro de référence ci-dessus - our par Email: prosupport@spinlock.co.uk

Remove the Powerclutch from the deck.
Carefully unscrew fasteners (A) from sidefaring (B).
Remove one sidefaring leaving components located on fasteners.
Note how parts are assembled before removing faulty parts.
Reassemble with new parts.
Check top pin (C) is well located in blind holes, it should not be able to move from side to side.
Check function of clutch before resealing to deck using our neoprene installation gasket (X-CASK) or silicone sealant.
If replacing plastic sideplates on a single clutch, ensure that top pin (C) is replaced with top pin included with sideplates.
If replacing plastic sideplates on a multiple clutch, top pin (C) will also need to be replaced, by a special part.
XT12 (double) = 3X067A
XT13 = 3X068A
XT14 = 3X107A
XT15 = 3X126A
For l'envoie sans frais de votre axe, veuillez contact Spinlock Direct, en indiquant le numéro de référence ci-dessus - our par Email: prosupport@spinlock.co.uk

Remove the Powerclutch from the deck.
Carefully unscrew fasteners (A) from sidefaring (B).
Remove one sidefaring leaving components located on fasteners.
Note how parts are assembled before removing faulty parts.
Reassemble with new parts.
Check top pin (C) is well located in blind holes, it should not be able to move from side to side.
Check function of clutch before resealing to deck using our neoprene installation gasket (X-CASK) or silicone sealant.
If replacing plastic sideplates on a single clutch, ensure that top pin (C) is replaced with top pin included with sideplates.
If replacing plastic sideplates on a multiple clutch, top pin (C) will also need to be replaced, by a special part.
XT12 (double) = 3X067A
XT13 = 3X068A
XT14 = 3X107A
XT15 = 3X126A
For l'envoie sans frais de votre axe, veuillez contact Spinlock Direct, en indiquant le numéro de référence ci-dessus - our par Email: prosupport@spinlock.co.uk

Remove the Powerclutch from the deck.
Carefully unscrew fasteners (A) from sidefaring (B).
Remove one sidefaring leaving components located on fasteners.
Note how parts are assembled before removing faulty parts.
Reassemble with new parts.
Check top pin (C) is well located in blind holes, it should not be able to move from side to side.
Check function of clutch before resealing to deck using our neoprene installation gasket (X-CASK) or silicone sealant.
If replacing plastic sideplates on a single clutch, ensure that top pin (C) is replaced with top pin included with sideplates.
If replacing plastic sideplates on a multiple clutch, top pin (C) will also need to be replaced, by a special part.
XT12 (double) = 3X067A
XT13 = 3X068A
XT14 = 3X107A
XT15 = 3X126A
For l'envoie sans frais de votre axe, veuillez contact Spinlock Direct, en indiquant le numéro de référence ci-dessus - our par Email: prosupport@spinlock.co.uk

Remove the Powerclutch from the deck.
Carefully unscrew fasteners (A) from sidefaring (B).
Remove one sidefaring leaving components located on fasteners.
Note how parts are assembled before removing faulty parts.
Reassemble with new parts.
Check top pin (C) is well located in blind holes, it should not be able to move from side to side.
Check function of clutch before resealing to deck using our neoprene installation gasket (X-CASK) or silicone sealant.
If replacing plastic sideplates on a single clutch, ensure that top pin (C) is replaced with top pin included with sideplates.
If replacing plastic sideplates on a multiple clutch, top pin (C) will also need to be replaced, by a special part.
XT12 (double) = 3X067A
XT13 = 3X068A
XT14 = 3X107A
XT15 = 3X126A
For l'envoie sans frais de votre axe, veuillez contact Spinlock Direct, en indiquant le numéro de référence ci-dessus - our par Email: prosupport@spinlock.co.uk

customer contact

Spinlock Ltd
Cowes
England

Fax: +44 (0) 1983 295542
Email: prosupport@spinlock.co.uk
Web: www.spinlock.co.uk

IMPORTANT
Spinlock limited accept no liability whatsoever for any claim that may relate directly or indirectly to the use of this equipment for any application or loading other than advised in current product information published by Spinlock Limited.

Attention de nos produits est destinée à un usage spécifique qui doit être conforme à nos normes mandataires. En cas de doute vous devez solliciter un complément d'information auprès de Spinlock Limited qui ne peut en aucun cas être tenue responsable des dégâts ou dommages directs ou indirects survenus lors de l'utilisation de ses produits.

Powerclutches
XT & XC (older XL & XR model upgrade)

XT & XC accessories

3R104A.1

XT & XC accessories

XT & XC accessories

XT & XC accessories

XT & XC accessories

XT & XC accessories

XT & XC accessories

XT & XC accessories

XT & XC accessories